



# Ranger™ Series

High Precision Industrial Counting Scales



## ***Outstanding Performance in the Most Demanding Applications!***

The OHAUS Ranger™ line of compact counting scales has been upgraded and expanded with new software and enhanced microprocessors for even better performance in demanding industrial applications. Every Ranger Count features a large, backlit LCD display with fast display of weighing results within 2 seconds, as well as an RS232 port for quick connectivity to printers and systems. For applications requiring additional filtering, the Ranger series now includes dynamic weighing software allowing weigh determination where vibration is an issue. For advanced counting applications, the Ranger Count Plus offers a numeric keypad for manual entry of key data like average piece weight (APW), sample size and part ID, and information stored in 100 memory locations.

Every Ranger is designed with OHAUS' easy-to-use software interface, making operation intuitive with a consistent feel across all four Ranger lines: Ranger, Ranger High Resolution, Ranger Count and Ranger Count Plus. No matter the industrial need, there is a Ranger for that application!

### ***Standard Features Include:***

- Ranger Count scales offer high performance strain gauge loadcells supporting resolutions to 1:30,000, while the Ranger Count Plus incorporates an MFR loadcell for resolutions up to 1:300,000
- Rugged cast aluminum housings with removable stainless steel weighing pans, tough painted finishes and sealed front panels
- Weigh in lb, oz, kg, g or metric tonne units
- Large, backlit LCD display
- RS232 interface included for connection to printers and systems
- NTEP 1:6,000 legal-for-trade resolution available on Ranger Count models, NTEP 1:30,000 legal-for-trade resolution available for Ranger Count Plus
- Built-in AC with hardwired plug
- Factory options for second RS232, analog input for connection to external bases, and rechargeable NiMH battery available

# Ranger™ Series High Precision Industrial

## Ranger Count

Designed for counting applications requiring ease-of-use and fast response, the Ranger Count combines simplified operation with a fast, precise weighing mechanism.

### Counting Modes

The Ranger Count can count into an empty container, starting with a sample. For bulk operations, the user can count out of a full container, starting with the removal of a sample. The Ranger Count includes software to ensure optimization of the APW (Average Piece Weight) sample (with selectable accuracies of 97.5%, 99% and 99.5%) and can be set to continue to optimize the APW during the counting process. Set sample sizes can be selected or the user can use a variable sample size to start counting, speeding use. The Ranger Count also can be set to clear the APW between containers, ensuring that each container starts with a new APW sample.

### Multiple Weighing Modes

For use in a range of industrial applications, the Ranger Count includes software for Filling/Dosing, allowing weighing of fine powders or liquids. For use with moving or unstable items, the Ranger Count can be set to weigh dynamically, providing an average of the item's weight over time. The Ranger Count can display the gross, net and tare weights stored in memory for checking tare weights during use.

### Two-Scale Counting

The Ranger Count can support two-scale counting using either the included RS232 port to other Ranger scales, or through an optional analog input option, for connection to larger platforms and floor scales. In two-scale mode, the Ranger Count displays the status of the bulk and reference scales on the large LCD.

### Outline Dimensions

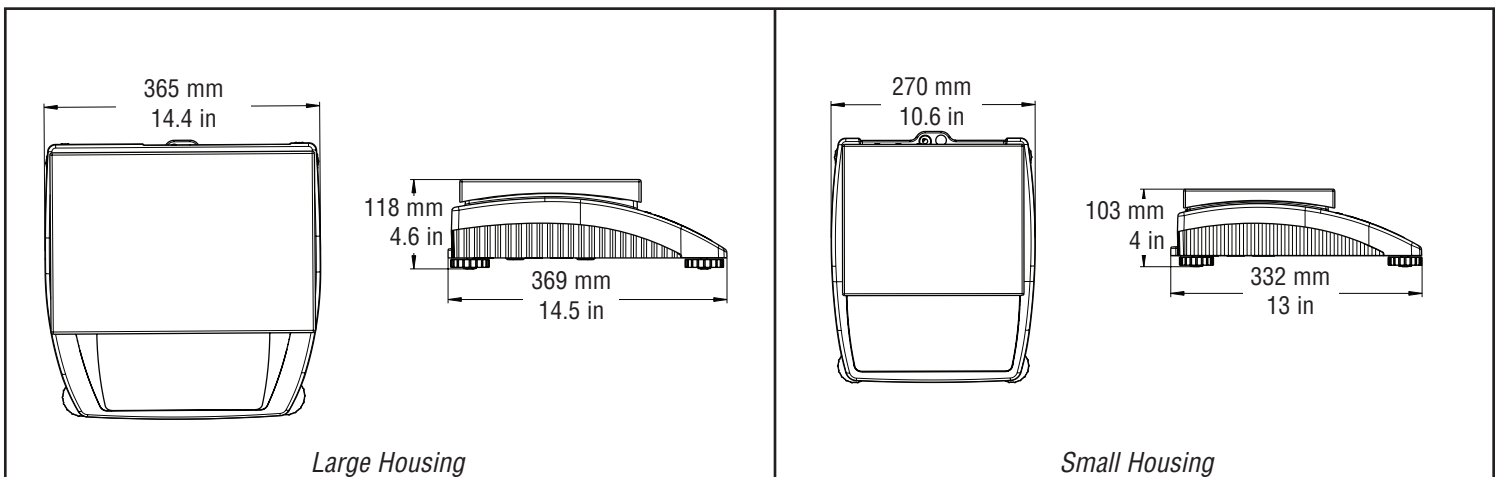

## Ranger Count Plus

Adding to the most of the features found in the Ranger Count, the Ranger Count Plus includes enhanced memory and features for supporting more demanding counting applications:

### High-Precision Loadcell

The Ranger Count Plus is based on a high-precision MFR loadcell, providing lab balance resolutions with industrial counting software and housings.

### Counting Modes

The Ranger Count Plus supports both Counting and Count Checking. The Ranger Count Plus can count into and out of an empty container, and the Ranger Count Plus can be set to notify the user when the count in the container is within a set range of pieces, allowing fast packaging operation. The Ranger Count Plus includes software to ensure optimization of the APW sample (accuracies of 97.5%, 99% and 99.5%) and can also be set to continue to optimize the APW during the counting process. Set sample sizes and variable sample sizes can be used, and the Ranger Count also can be set to clear the APW between containers.

### 100 Memory Locations

The Ranger Count Plus also features 100 memory locations for storing information by ID number for tare weights, APWs and reference quantities for target weights and target quantities.

### Multiple Weighing Modes

For use in a range of industrial applications, the Ranger Count includes software for Filling/Dosing, Dynamic Weighing, Count Checking (ensuring a part count is within a set limit), Checkweighing (ensuring a weight is within a set limit), and Accumulation/Totalization using the dedicated +/- key.

### Two-Scale Counting

The Ranger Count can support two-scale counting either to other Ranger scales via RS232, or through an optional analog input option to larger platforms and floor scales.

### Other Standard Features

Selectable settings for auto-zero tracking, retain zero and tare when off, chain tare, auto tare, clear auto tare, averaging and stability levels, backlight, sleep mode and auto-off timer, RS232 settings, print mode and command sets (Ohaus, MT-SICS and Toledo Continuous). Ranger Count Plus also supports time/date with LCD display and GMP/GLP-compliant data output, as well as selectable key beep.

### Compliance

- **Electrical/Emissions:** CE listed, meets AS/NZS4251.1 Emission/AS/NZS4252.1 Immunity, FCC Class B Part 15 operation, Industry Canada Class A. cULus AC power pack. Compliant to Directive 2002/96/EC on waste electrical and electronic equipment (WEEE).
- **Legal-for-Trade:** NTEP Certified (weighing function only – certificate #07-026, Class II for Ranger Count Plus, Class III for Ranger Count), OIML R76 Class III and EC Type Approved.
- **Quality:** Ohaus quality management system registered to ISO 9001:2008

# Ranger™ Series Precision Counting Scales

## Ranger Count Plus

Model	RP3RM	RP6RM	RP15LM	RP35LM
Capacity x Readability Default	6.61388 x 0.00002 lb 105.8228 x 0.0002 oz 3 x 0.00001 kg 3000 x 0.01 g	13.22770 x 0.00005 lb 211.6440 x 0.0005 oz 6 x 0.00002 kg 6000 x 0.02 g	33.0694 x 0.0001 lb 529.110 x 0.002 oz 15 x 0.00005 kg 15,000 x 0.05 g	77.1620 x 0.0002 lb 1234.592 x 0.002 oz 35 x 0.0001 kg 35,000 x 0.1 g
Minimum APW	0.000005 lb 0.0001 oz 0.002 g	0.00001 lb 0.00005 oz 0.005 g	0.00005 lb 0.0002 oz 0.01 g	0.00002 lb 0.0002 oz 0.05 g
Capacity x Readability NTEP Certified (NTEP Certification not for Counting Function)	6 x 0.0002 lb 3 x 0.0001 kg	12 x 0.0005 lb 6 x 0.0002 kg	30 x 0.001 lb 15 x 0.0005 kg	60 x 0.002 lb 30 x 0.001 kg
Platform Size (W x D)	6.4 x 6.4 in / 16.2 x 16.2 cm	9.5 x 8 in / 24 x 20 cm	14 x 9.5 in / 35 x 24 cm	
Scale Dimensions (W x D x H)	10.5 x 13.2 x 4 in / 26.5 x 33.5 x 10 cm		14.2 x 14.6 x 4.5 in / 36 x 37 x 11.5 cm	
Net (Shipping) Weight	12 lb / 5.1 kg (15 lb / 6.7 kg)		24 lb / 10.6 kg (29 lb / 12.8 kg)	
Shipping Dimensions (W x D x H)	16.5 x 19 x 10 in / 42 x 48 x 25 cm		20 x 20.5 x 10.5 in / 52 x 53 x 27 cm	

## Ranger Count

Model	RC3RS	RC6RS	RC12LS	RC30LS	RC60LS
Capacity x Readability Default	6.6138 x 0.0002 lb 105.822 x 0.002 oz 3 x 0.0001 kg 3000.0 x 0.1 g 0.003 x 0.000001 t	13.2275 x 0.0005 lb 211.640 x 0.005 oz 6 x 0.0002 kg 6,000.0 x 0.2 g 0.006 x 0.000001 t	26.456 x 0.001 lb 423.30 x 0.02 oz 12 x 0.0005 kg 12,000.0 x 0.5 g 0.012 x 0.000001 t	66.138 x 0.002 lb 1,058.20 x 0.02 oz 30 x 0.001 kg 30,000 x 1 g 0.03 x 0.000001 t	132.275 x 0.005 lb 2116.50 x 0.05 oz 60 x 0.002 kg 60,000 x 2 g 0.06 x 0.000002 t
Minimum APW	0.00002 lb 0.0005 oz 0.01 g	0.00005 lb 0.001 oz 0.02 g	0.0001 lb 0.002 oz 0.05 g	0.0002 lb 0.005 oz 0.1 g	0.0005 lb 0.01 oz 0.2 g
Capacity x Readability NTEP Certified (NTEP Certification not for Counting Function)	6 x 0.001 lb 3 x 0.0005 kg 3,000 x 0.5 g	12 x 0.002 lb 6 x 0.001 kg 6,000 x 1 g	24 x 0.005 lb 12 x 0.002 kg 12,000 x 2 g	60 x 0.01 lb 30 x 0.005 kg 30,000 x 5 g	120 x 0.02 lb 60 x 0.01 kg 60,000 x 10 g
Platform Size (W x D)	9.5 x 8 in / 24 x 20 cm		14 x 9.5 in / 35 x 24 cm		
Scale Dimensions (W x D x H)	10.5 x 13.2 x 4 in / 26.5 x 33.5 x 10 cm		14.2 x 14.6 x 4.5 in / 36 x 37 x 11.5 cm		
Net (Shipping) Weight	12 lb / 5.1 kg (15 lb / 6.6 kg)		20 lb / 8.9 kg (25 lb / 11.1 kg)		
Shipping Dimensions (W x D x H)	16.5 x 19 x 10 in / 42 x 48 x 25 cm		20 x 20.5 x 10.5 in / 52 x 53 x 27 cm		

## Specifications

	Ranger Count	Ranger Count Plus
Maximum Internal Counting Resolution	1:600,000	1:3,000,000
Maximum Displayed Counting Resolution	1:300,000	1:1,500,000
Weighing Units	lb, oz, kg, g, t	
Application Modes	Weigh, Count, Fill/Dose, Dynamic Weigh, Gross/Net/Tare	Weigh, Count, Fill/Dose, Dynamic Weigh, Checkweigh, Count Check, Totalize
Display	Backlit LCD with 7 digits 0.63"/16mm high and capacity guide	
Memories	N/A	100 for tare weights, APW, and target values
Keyboard	10 keys	10 keys plus numeric keypad
Interface	RS232	RS232 with GMP/GLP data output
Tare Range	To full scale capacity	
Stabilization Time	~ 1 second	
Auto-Zero Tracking	0.5, 1, 2, 5, 10d or Off	
Safe Overload Capacity	150% of capacity	
Power	Internal, hardwired AC included	
Calibration	Span Calibration: 0%, 20% to 100% of capacity	
Operating Temperature	14° to 104°F / -10° to 40°C	50° to 86°F / 10° to 30°C

## Factory Options

NiMH Battery	Add /1 to model listed above
2nd RS232	Add /2 to model listed above
NiMH Battery and 2nd RS232	Add /3 to model listed above
Analog Input	Add /4 to model listed above
NiMH Battery and Analog Input	Add /5 to model listed above

### OHAUS CORPORATION

\* 7 Campus Drive  
Suite 310  
Parsippany, NJ 07054 USA

Tel: 800.672.7722  
973.377.9000  
Fax: 973.944.7177

[www.ohaus.com](http://www.ohaus.com)

With offices throughout Europe,  
Asia, and Latin America

\* ISO 9001  
Registered Quality Management System

