



Navigator™ XT

Portable Scales



The Only Scale in its Class with Touchless Sensors That Free Up Your Hands!

OHAUS raises the bar in value-oriented scales...again! The Navigator™ XT series offers a unique combination of features including touchless sensors, ultra-fast response time and superior overload protection for use in a wide variety of weighing applications.

Standard Features Include:

- **Touchless Sensors** – Navigator XT is designed with two touchless sensors which free up your hands so you can focus on handling samples. The touch-free control of the zero, print, function, tare, backlight and off operations help to avoid transferring sample residue to the keypad. In addition, the two sensors can be set up independently to control up to 36 combinations of operations.
- **One Second Stabilization Time** – Navigator XT is designed to accurately stabilize in less than one second providing fast and accurate weighing results, improving operator efficiency, productivity and throughput.
- **Superior Overload Protection** – Navigator XT is designed with a superior mechanical overload protection system that allows the scale to withstand loads up to 400% of its rated capacity. This prevents damage to the scale and helps it withstand undue shock or overloading. In addition, an integrated shipping lock further protects the load cell from damage during transportation or storage.
- **Multiple Application Modes** – Navigator XT is designed for versatility. Multiple application modes such as: counting, percent weighing, checkweighing, display hold and accumulation/totalization address a wide range of use in quality control, inventory management, shipping and receiving, recipes and formulation, portioning and other popular applications.

Navigator™ XT *Portable Scales*

With its best-in-class combination of features, versatility and performance, the OHAUS Navigator offers a wide range of use in industrial, food and laboratory weighing applications.

Unsurpassed Cleanliness

- Designed with two touchless sensors that free up your hands, allowing you to focus on handling samples and keeping the scale free from contaminants. The touch-free control of tare, zero, print, function and display back-light helps to minimize touching the keypad, thereby avoiding cross-contamination or unwanted residue on or from the scale.
- A polished stainless steel pan, corrosion-free plastic housing and spill-resistant pan sub-assembly embodies a hygienic design that is easy to clean.
- The optional full-body in-use cover wraps over and around the housing and keypad to guard against spills, dust and contamination.

Unmatched Productivity

- Amazing stabilization in less than one second to provide fast, accurate and repeatable weighing results; improving operator efficiency and increasing productivity.
- Includes an internal rechargeable lead acid battery that operates up to 100 hours (or over twelve 8-hour days) of normal use on a full charge. With maximized portability, the scale can be transported and used where power outlets are not readily available.
- A wave of the hand over the touchless sensors eliminates the extra effort or time to press the keys.
- A bright backlit LCD display provides optimum visibility in any lighting condition – indoors or out – with large digits and indicators that make it fast and easy to read the weighing results.

Unbeatable Durability

- Built to handle to serious loads, the superior mechanical overload protection system enables the scale to safely bear loads up to 4 times its rated capacity.
- Constructed of a high-strength 304 type stainless steel pan and impact-resistant ABS plastic housing that helps the scale stand up to years of use or abuse.
- The touchless sensors minimize keypad use, reducing operational wear and tear.

Features

Internal Rechargeable Battery

Enhance mobility by being able to work anywhere! The sealed lead acid battery operates up to 100 hours on a full charge to minimize battery replacement and reduce maintenance costs.



Security Bracket

The integral security bracket accommodates the optional locking cable to secure the scale to a workstation.



Optional RS232, USB or Ethernet Interface Kits

These easily installed user options allow connecting the scale to peripheral devices for printing and/or data collection. The connecting cable is integrated in each kit, eliminating the need for additional interface cables.



Backlit Display

The bright backlit LCD provides optimal visibility in any lighting condition. Used indoors or outdoors, the large digits and indicators make the weighing results easy to read.

Transportation Lock

The transportation lock prevents undue pressure on the load cell during transportation and storage. Unlock before use and lock when moving around different locations.

Touchless Sensors

Two touchless infrared sensors can be set up independently to operate up to 36 combinations of operations without touching the keys. Sensors control: Tare, Zero, Print, Function and Display Backlight.

Menu Lock Switch

A menu lock switch acts as an extra supervisor control to prevent unwanted changes to protected scale settings. Simply set up the scale to meet your specific needs then slide the lock switch to avoid changes in calibration.



Illuminated Up-front Level Indicator

The integral level bubble is illuminated at power up to aid in visibility, and serves as a reminder to level the scale prior to use.



Skid-Resistant Leveling Feet

Independently adjustable, the feet also have skid-resistant rubber pads to provide superior stability, and vibration resistance.



Outline Dimensions

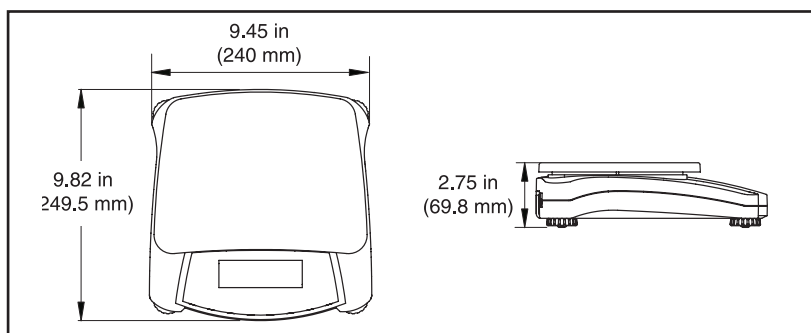

Navigator™ XT Portable Scales

Specifications

Model	NVT1601/1	NVT3201/1	NVT6401/1	NVT10001/1	NVT16000/1
Capacity x Maximum Displayed Readability	1,600 g x 0.1 g 3.2 lb x 0.0002 lb 51 oz x 0.005 oz or 1/8 oz 1.6 kg x 0.0001 kg	3,200 g x 0.2 g 6.4 lb x 0.0005 lb 102 oz x 0.01 oz or 1/8 oz 3.2 kg x 0.0002 kg	6,400 g x 0.5 g 16 lb x 0.001 lb 256 oz x 0.02 oz or 1/8 oz 6.4 kg x 0.0005 kg	10,000 g x 0.5 g 22 lb x 0.002 lb 352 oz x 0.05 oz or 1/8 oz 10 kg x 0.0005 kg	16,000 g x 1 g 32 lb x .002 lb 515 oz x 0.05 oz or 1/8 oz 16 kg x 0.001 kg
Displayed Resolution	1:16000	1:16000	1:16000	1:20000	1:16000
Repeatability / Linearity	0.1g / ±0.2g	0.2g / ±0.4g	0.5g / ±1g	0.5g / ±1g	1g / ±2g
Span Calibration Mass	2 lb / 1 kg	2 lb / 2 kg	10 lb / 5 kg	10 lb / 5 kg	20 lb / 10 kg
Linearity Calibration Mass	2, 3 lb / 1, 1.5 kg	2, 5 lb / 2, 3 kg	10, 15 lb / 3, 6 kg	10, 20 lb / 5, 10 kg	20, 30 lb / 10, 15 kg
Calibration	User-selectable external span or linearity calibration / Digital with external weight				
Weighing Units	Gram, Kilogram, Pound, Ounce (decimal/fractional), Pound:Ounce (decimal/fractional ounce), Troy Ounce, Grain, Newton, Carat, Pennyweight, Tael (Hong Kong, Taiwan, Singapore), Tical, Tola				
Application Modes	Weighing, Percent Weighing, Parts Counting (min APW 1d), Checkweighing, Display Hold, Accumulation/Totalization				
Display	0.78 in. / 20 mm high, 6-digit, 7-segment LCD with white LED backlight				
Checkweigh Indicators	Over-Accept-Under LCD annunciators				
Keyboard	4 mechanical keys, raised and with tactile feedback / 2 touchless sensors				
Leveling Adjustment	Front-mounted level bubble with illumination / adjustable leveling feet with skid-resistant rubber pads				
Ingress Protection	IP43				
Tare Range	Full capacity by subtraction				
Stabilization Time	≤1 second				
Overload Capacity	400% of rated capacity				
AC Power	12VDC 0.42A AC adapter (included), 100-240V 0.25A 50-60Hz				
Battery	Internal rechargeable lead acid battery, 6V 1.2AH (100-hour typical operation with 12-hour full charge cycle)				
Power Conservation	User-enabled auto power-off after 5 minutes of inactivity				
Operating Temperature	50° F to 104° F / 10° C to 40° C at 20% to 85% relative humidity, non-condensing				
Pan Size (W x D)	9 in. x 6.9 in. / 230 mm x 174 mm				
Scale Dimensions (W x D x H)	9.5 x 9.8 x 2.8 in. / 240 x 250 x 70 mm				
Shipping Dimensions (W x D x H)	15.2 x 13.2 x 6.7 in. / 385 x 335 x 170 mm				
Net Weight	4.3 lb / 2.0 kg				
Shipping Weight	6.1 lb / 2.8 kg				

Accessories

OHAUS Number

RS232 Interface Kit, Navigator Series.....	83032107
USB Interface Kit, Navigator Series	83032108
Ethernet Interface Kit, Navigator XT.....	83032109
In-Use Cover, Navigator XT	83032221
Carrying Case, Navigator XT	83032224

Compliance

- **Electromagnetic Compatibility:** C-Tick, CE Class B, FCC Class B, ICES-003 Class B
- **Safety (AC adaptors only):** C-Tick, CCC, CE, cCSAus, KTL, PSE, TUV-GS
Compliant to Directive 2002/96/EC on waste electrical and electronic equipment (WEEE)
Compliant to Directive 2002/95/EC on the restriction of the use of certain hazardous substances in electrical and electronic equipment (RoHS)
- **Quality:** OHAUS quality management system registered to ISO 9001:2008

OHAUS CORPORATION

* 19A Chapin Road
P.O. Box 2033
Pine Brook, NJ 07058 USA

Tel: 800.672.7722
973.377.9000
Fax: 973.944.7177

www.ohaus.com

With offices throughout Europe,
Asia, and Latin America

* **ISO 9001**
Registered Quality Management System

80774559 © Copyright Ohaus Corporation

