



RE Series

Standard Price Computing Scale



Model RE shown with rear display (top) and tower mount model (bottom)



Precision, Consistency and OHAUS Reliability

The low profile OHAUS RE Series standard price computing scale meets most weighing needs for the cost conscious retailer. The RE Series is highly versatile and portable, with its battery operation and price computing features such as: 100 PLU memory, 24 pre-set keys, By-Count pricing and Fractional pricing. This makes the RE Series ideal for applications including mobile businesses, retail sale of fruits & vegetables, meats and cheese, delicatessens, confectionery, coffee and tea and portion control. Easy to operate, easy to clean and requiring minimum maintenance, the RE Series has everything you need in a standard retail price computing scale.

Standard Features Include:

- High-grade polymer housing with removable stainless steel pan
- Large, easy-to-read backlit LCD displays (tower model RE15CUS with adjustable angle tower display)
- Numeric, 32-key positive feedback membrane switch with key-press beeper
- Separate Tare and Zero function keys
- Unit price storage up to 100 PLU
- 24 preset memory keys for quick recall with customizable pull-out card
- Total price hold
- Pre-pack mode
- By-Count price computing function
- Fractional pricing
- Accumulation of total price
- Battery operation with Auto-shut off and Sleep mode power saving features
- NTEP approved 3,000d resolution

RE Series Standard Price Computing Scale

Specifications

Model	RE15US	RE30US	RE15CUS
NTEP Certified Capacity x Readability	30 lb x 0.01 lb	60 lb x 0.02 lb	30 lb x 0.01 lb
NTEP Certified Resolution	3,000d		
Construction	High-grade polymer housing with stainless steel pan		
Pan Dimensions (W x D)	9.5 x 13.5 in / 242 x 342 mm		
Leveling Components	4 adjustable rubber feet with integral front mounted level bubble indicator		
Display	Backlit LCD, 6-digit, 7-segment, 0.55 in / 13.5 mm high characters, Weight - Unit Price - Total Price		Front and tower
Weighing Units	lb		
Application Modes	100 PLU memory, 24 pre-set keys, by-Count Pricing, Fractional Pricing, Pre-Pack Mode, Accumulation		
Keyboard	Numeric, 32-key tactile membrane switch with key-press beeper		
Calibration Weight	2/3 and full scale capacity		
Tare Range	To full capacity by subtraction		
Zero Range	At power-on: $\pm 10\%$ / keyboard: $\pm 2\%$ full scale capacity		
Stabilization Time	Within 2 seconds		
Power	12VDC 800mA AC Adapter (included) / 6 D-cell alkaline batteries (not included)		
Battery Operation	60 - 70 hours of continuous use		
Safe Overload	150% of full scale capacity		
Operating Temperature Range	14°F to 104°F / -10°C to 40°C		
Storage Temperature Range	-13°F to 122°F / -25°C to 50°C		
Humidity Range	80% max up to 88°F / 31°C, decreasing linearly to 50% at 104°F/40°C		
Shipping Dimensions (W x D x min H)	18.3 x 16.5 x 8.7 in / 465 x 419 x 221 mm	17.8 x 16.4 x 8.7 in / 452 x 417 x 221 mm	
Scale Unit Weight	7.8 lb / 3.5 kg	9.0 lb / 4.1 kg	
Shipping Weight	12.0 lb / 5.5 kg	13.4 lb / 6.1 kg	

Outline Dimensions

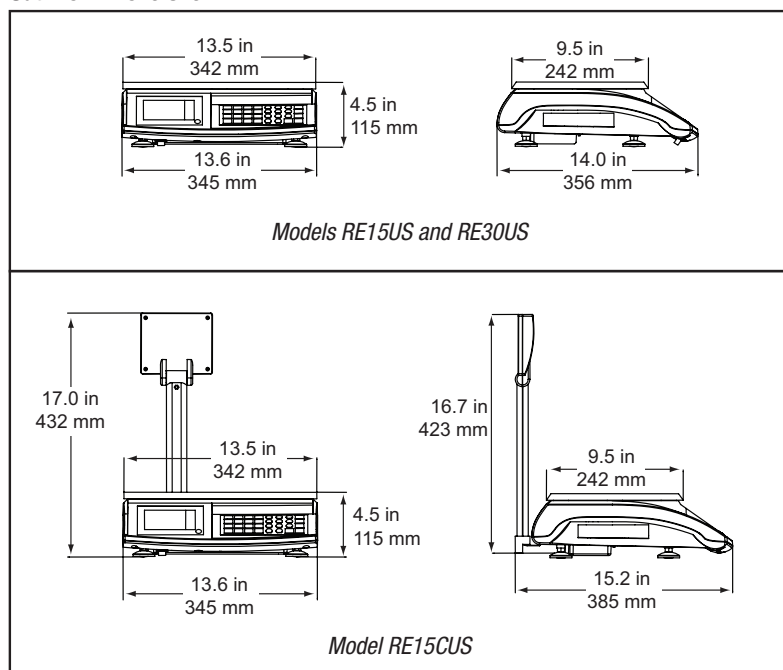

OHAUS CORPORATION

* 7 Campus Drive
Suite 310
Parsippany, NJ 07054 USA

Tel: 800.672.7722
973.377.9000
Fax: 973.944.7177

www.ohaus.com

With offices throughout Europe,
Asia, and Latin America

* ISO 9001
Registered Quality Management System

Compliance

- **Safety and EMC:** EN60950, EN61326, FCC, CE, cUL_{US}
- **Legal-For-Trade:** NTEP CC No. 08-057
- **Quality:** OHAUS quality management system registered to ISO 9001:2008